

# DMT340 Series Dewpoint and Temperature Transmitters for Low Dewpoint Applications

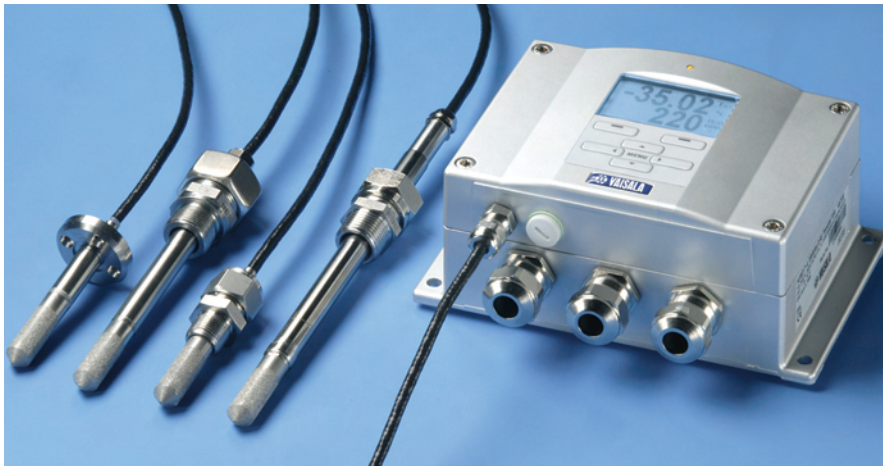

*The DMT340 transmitter family has the solution for demanding industrial dewpoint measurements.*

The Vaisala DRYCAP® Dewpoint and Temperature Transmitter Series DMT340 is designed for industrial low humidity applications. Typical applications include compressed air drying and metal treatment. The device is very reliable, easy to use and economical to maintain.

## Stability in low dewpoints

The Vaisala DRYCAP® Sensor is immune to particulate contamination, water condensation, oil vapor and most chemicals. Since the sensor withstands condensation, its performance is unmatched for low dewpoint applications that experience water spikes in the process. The sensor recovers rapidly from contact with free water.

## Patented auto-calibration

The stability of the DMT340 is due to the unique auto-calibration function, patented by Vaisala. The auto-calibration makes the transmitter perform a calibration and adjustment by itself while the measured process is running. If the measurement accuracy is not confirmed, corrections are made automatically. The procedure is so quick and corrections are so minor that



*The display shows measurement trends, real time data and history.*

it will go unnoticed. This ensures low maintenance and high performance. To continue performance at the highest level, the transmitter can be sent to Vaisala for a NIST traceable calibration. Calibration intervals depend on the application; in normal conditions, a NIST traceable calibration in every two years is recommended.

## Graphical measurement trend and history display

The DMT340 can be ordered with a large numerical and graphical display with a multilingual menu. It allows the user to monitor measurement trends and one-year history. The optional data logger with real-time clock makes it possible to generate more than four years of measured

## Features/Benefits

- Measures dewpoints from -60 °C to +80 °C (-76 ... +176 °F) with the accuracy of ±2 °C (±3.6 °F)
- Vaisala DRYCAP® Sensor provides accurate, reliable measurement with excellent long-term stability and fast response
- Withstands condensation
- Unique auto-calibration feature
- Optional alarm relays, local display and mains power supply module
- Compatible with Vaisala DRYCAP® Hand-Held Dewpoint Meter DM70
- NIST traceable (certificate included)
- 3 analog outputs and a serial interface

history and zoom in on any desired time or time frame. The battery backup of the real-time clock guarantees a reliable logging of measured data.

## Versatile outputs

The DMT340 can have up to three analog outputs. Galvanic isolation of supply power and analog outputs is also available. For serial interface the USB connection, RS232 and RS485 can be used. Additionally alarm relay option is available.

## Easy installation

The DMT340 has a variety of features to choose from. Units are delivered installation-ready.

*The Vaisala DRYCAP® HandHeld Dewpoint Meter DM70 is ideal for field checking DMT340 transmitters.*





The DMT342 probe is installed using a flange or sampling cell. The small probe is ideal for integrating into larger equipment.

**DMT342 with Small Size Flanged Probe**

Pressure range 0 ... 50 bar / 0 ... 725 psia  
 Mechanical durability up to 250 bar / 3625 psia  
 Probe diameter 12 mm / 0.5 inch  
 Installation Flange 36 mm / 1.4 inch  
 Sampling cell HMP302SC

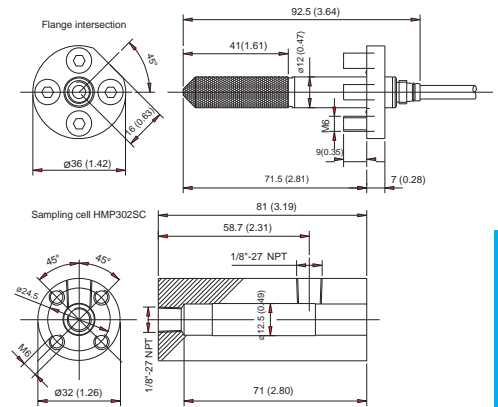

The DMT344 features a threaded connection for extended pressures with different fitting body options. It is ideal for permanent installations into pressurized or vacuum processes.

**DMT344 with Probe for High Pressures**

Pressure range 0 ... 50 bar / 0 ... 725 psia  
 Mechanical durability up to 100 bar / 1450 psia  
 Probe diameter 12 mm / 0.5 inch  
 Installation Fitting Body M22 x 1.5  
 Fitting Body NPT 1/2"

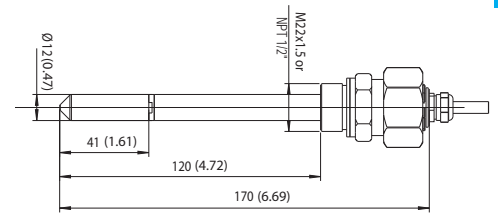

The DMT347 probe is ideal for tight spaces with thread connection. The small probe is installed using the threaded fitting bodies.

**DMT347 with Small Sized Probe**

Pressure range 0 ... 10 bar / 0 ... 145 psia  
 Mechanical durability up to 10 bar / 145 psia  
 Probe diameter 12 mm / 0.5 inch  
 Installation Fitting Body R 3/8" ISO  
 Fitting Body G 1/2" ISO  
 Fitting Body NPT 1/2"

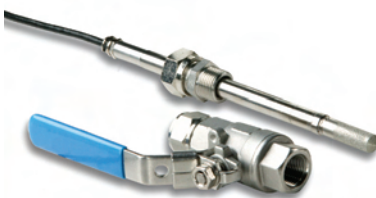
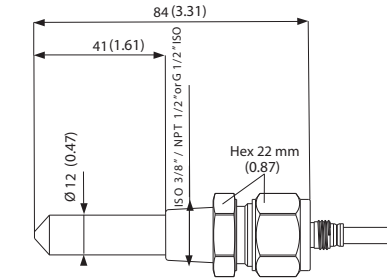

The DMT348 is ideal for installations in pressurized processes where the probe needs to be removed while the process is running. The probe depth is adjustable.

**DMT348 with Probe for Pipeline Installations**

Pressure range 0.40 bar / 0.580 psia  
 Adjustable length 41..149/371 mm / 1.61..5.87/14.6 inch  
 Installation Fitting Body R1/2" ISO  
 Fitting Body NPT 1/2"  
 Ball Valve Set BALLVALVE-1  
 Sampling Cell DMT 242SC or DMT242SC2

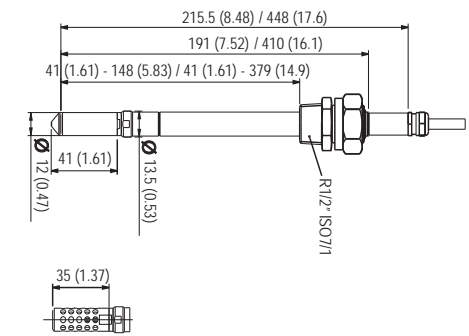

Optional filter for low pressures (for all models)