



Manostats (pressure switches) PST

- Measuring ranges from -500/+1000 Pa to -1000/+2000 mbar
- RCR relay output 3A/230 Vac. Power supply 24 Vac/Vdc
- Visual alarm, red LED in front
- ABS IP65 housing, with display
- Quick and easy mounting with the "1/4 turn" system with wall-mount plate

■ Features of the transmitter

Pressure

Working principle : a piezoresistive sensitive element creates a proportional voltage from the pressure applied on the sensor.

Measuring range	see "Part number"
Unit of measurement	Pa, mmH ₂ O, mbar, inWG, mmHG (PST-1 and PST-2) mbar, inWG, mmHG, KPa, PSI (PST-3 and PST-4)
Accuracy*	±2% of reading ± 3 Pa (PST-1) ±2% of reading ± 3 mmH ₂ O (PST-2) ±2% of reading ± 3 mbar (PST-3 and PST-4)
Response time	0,3 s
Resolution	1 Pa-0,1 mmH ₂ O-0,01 mbar-0,01 inWG-0,01 mmHG (PST-1 and PST-2) 1 mbar-0,1 inWG-1 mmHG -0,1 KPa- 0,1 PSI (PST-3 and PST-4)
Autozero	manual with push-button
Type of fluid	air and neutral gases
Overpressure tolerated	25000 Pa (PST-1), 7000 mmH ₂ O (PST-2), 1400 mbar (PST-3), 3000 mbar (PST-4).

■ Features of the housing

Housing	ABS
Fire-proof classification	HB as per UL94
Dimensions	see drawing
Protection	IP65
Display	5-digit LCD. Dimensions 50 x 15 mm
Height of the digits	10 mm
Connections	barbed fittings Ø 6,2 mm (PST-1 and PST-2) compression fittings Ø 4 x 6 mm (PST-3 and PST-4)
Cable grip	for cable Ø 7 mm max.
Weight	145 g

■ Technical specifications

Output	1 RCR relay 3 A/230 Vac
Relay and alarm status	red LED in front
Set point	1 configurable set point
Power supply	24 Vac/Vdc ±10%
Consumption	2 VA
Electro-magnetical compatibility	EN 61326
Electrical connection	Screw terminal block for cables Ø1.5 mm ² max.
Communication to PC	Kimo RS 232 cable
Working temperature	0 to +50°C
Storage temperature	-10 to +70°C
Environment	air and neutral gases

*All the accuracies indicated in this technical datasheet were stated in laboratory conditions, and can be guaranteed for measurements carried out in the same conditions, or carried out with calibration compensation.

■ Part number

To order, just add the range code to complete the part number :

Measuring range

1	-500 to +1000 Pa
2	-500 to +1000 mmH ₂ O
3	-250 to +500 mbar
4	-1000 to +2000 mbar

PST-

Example : PST-3 corresponds to a PST manostat with measuring range from -250 to + 500 mbar.

■ Dimensions of the housing

(including the wall-mount plate)

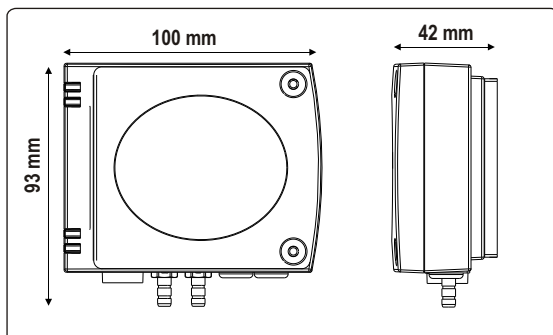

Connection

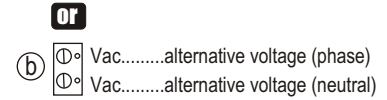
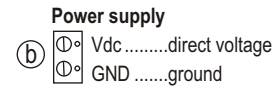
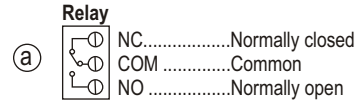
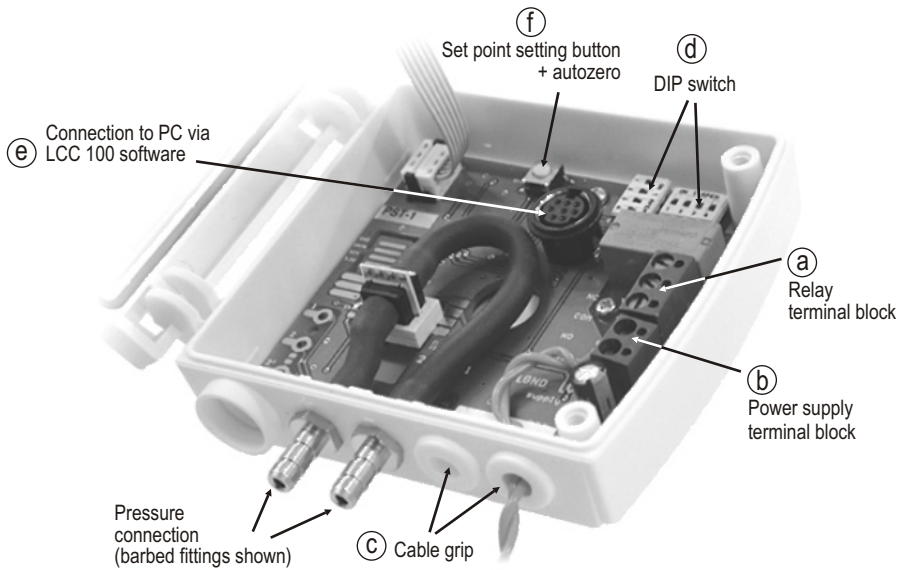

(c) Cable grip: to insert the cable, it is required to slightly cut the rubber.

Electrical connections - as per norm NFC15-100

This connection must be made by a qualified technician. To make the connection, the transmitter must not be energized.

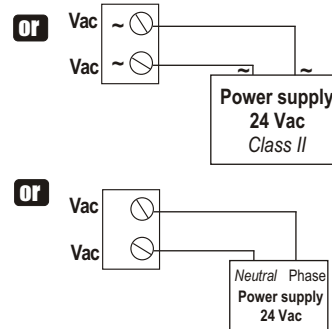
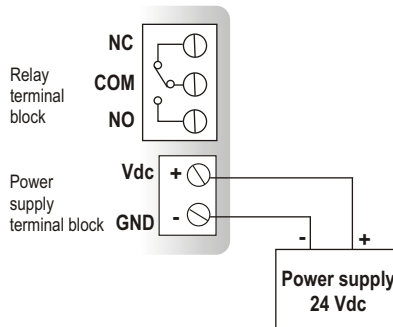

Autozero

To make an autozero, disconnect the 2 pressure connections and briefly press on the push-button. The following message will display :

push button

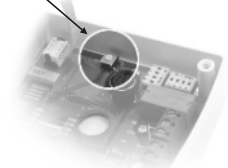

Configuration

Configuration of measuring units, set points, can be carried out different ways : **DIP switch, push-button and/or software** (connections (e), (f) and (d) on drawing "connection").

Configuration of measuring units by DIP switch

To configure the transmitter, please unscrew the 2 screws from the housing, and then open it.

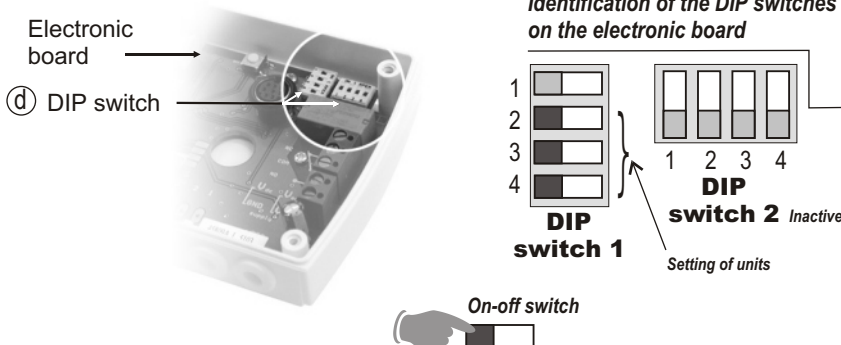

To configure the transmitter, **it must not be energized**. Then, you can make the settings required, thanks to the DIP switches (as shown on the drawing beside). When the transmitter is configured, you can power it up.

Caution !

Please follow carefully the combinations beside with the DIP switch.

If the combination is wrongly done, the following message will appear on the display of the transmitter "CONF ERROR". In that case, you will have to unplug the transmitter, replace the DIP switches correctly, and then power the transmitter up.

•Setting of units

To set the measuring unit, please set the on-off switches 2, 3 and 4 of the units, as shown beside.

Configurations	Pa	mmH ₂ O	mbar	inWG	mmHG	KPa	PSI	
Combinations	1 <input type="checkbox"/> 2 <input type="checkbox"/> 3 <input type="checkbox"/> 4 <input type="checkbox"/>	1 <input type="checkbox"/> 2 <input type="checkbox"/> 3 <input type="checkbox"/> 4 <input type="checkbox"/>	1 <input type="checkbox"/> 2 <input type="checkbox"/> 3 <input type="checkbox"/> 4 <input type="checkbox"/>	1 <input type="checkbox"/> 2 <input type="checkbox"/> 3 <input type="checkbox"/> 4 <input type="checkbox"/>	1 <input type="checkbox"/> 2 <input type="checkbox"/> 3 <input type="checkbox"/> 4 <input type="checkbox"/>	1 <input type="checkbox"/> 2 <input type="checkbox"/> 3 <input type="checkbox"/> 4 <input type="checkbox"/>	1 <input type="checkbox"/> 2 <input type="checkbox"/> 3 <input type="checkbox"/> 4 <input type="checkbox"/>	1 <input type="checkbox"/> 2 <input type="checkbox"/> 3 <input type="checkbox"/> 4 <input type="checkbox"/>
PST-1 and PST-2	X	X	X	X	X			
PST-3 and PST-4			X	X	X	X	X	

■ Set points configuration with the push-button

Power the transmitter up : it will then display its current configuration.
To modify the configuration, please proceed as follows :
Remove the 2 screws from the housing and open it.
The settings are done with the button located on the electronic board (see photo beside).

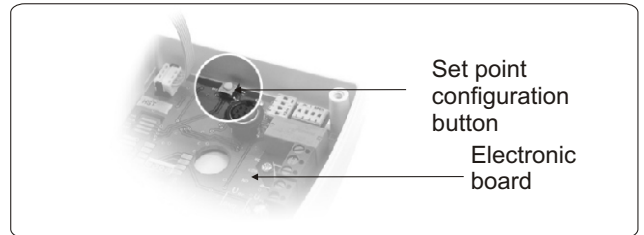

Principle :

- By pressing on this button for more than 3 seconds, you can validate the setting and go to the next setting.
- By pressing quickly on this button, you can increment a value and scroll down the different options or values.

This button enables :

1- to activate/deactivate an alarm (set point)

RL.ON ▶ RL.OFF ▶

2- to program the action of the alarm (rising/falling/regulation action)

3- to set the set point value

0000.0 ▶

4- to set the time-delay (temporisation)

00.SEC ▶

To set the different options :

1- Activating/deactivating the alarm :

After pressing the set point configuration button for more than 3 seconds, **CONF.** will be displayed, then **RL.ON** or **RL.OFF** (depending on the last configuration of the transmitter).

Afterwards, by briefly pressing on this button, you can switch between **RL.ON** (alarm on) and **RL.OFF** (alarm off).

To validate your choice, press again for 3 seconds. If you chose **RL.OFF**, then you will exit the configuration mode and switch back to the measurement mode. If you chose **RL.ON**, you will move to the next parameter.

2- Programming the action of the alarm (rising/falling/regulation action) :

Rising action (1 set point) : the alarm will activate when the measure **exceeds** the set point and will stop when the measure goes **below** the set point.

Falling action (1 set point) : the alarm will activate when the measure goes **below** the set point and will stop when the measure goes **above** the set point.

Regulation mode (2 set points) : the set point values will determine the action type. Two possibilities are available:

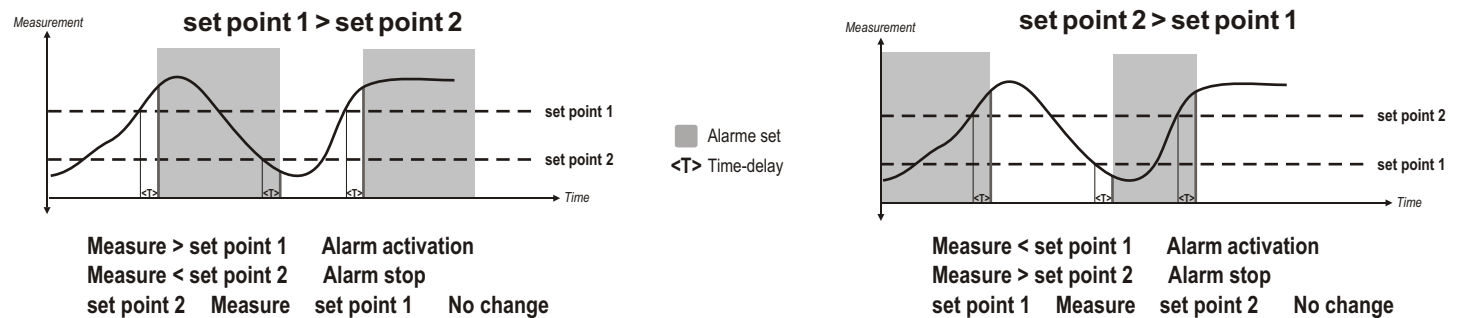

Press the button for 3 seconds to confirm your choice. You will then move on to the last parameter.

3- Programming the set point value :

The set point is a limit which, when being reached and/or exceeded, activates the relay and the visual red LED alarm.

The first digit will start to blink, by briefly pressing on the button, you can choose if the set point will be either positive (0) or negative (-). Then press the button during 3 seconds to confirm your choice. The second digit will start to blink. Press the button briefly to change the value. Then press the button during 3 seconds to confirm your choice. Repeat this sequence until you have reached the last digit and then confirm the set point. If you selected regulation mode , you will program the second set point.

4- Setting of the time-delay (dead band temporisation 60 sec max) :

When the set point is reached and/or exceeded, the time-delay will wait the specified time before energizing the relay, if the set point is still reached and/or exceeded.

When the first digit starts blinking, press briefly on the button to change the value. Then press the button during 3 seconds to confirm your choice. Repeat the process until all digits have the desired value and press the button for 3 seconds to confirm your choice.

The programming is now done and the display switches back to the measurement mode.

■ Initialization of the transmitter

When the transmitter is powered up, it initializes and displays the digits $\overline{00000}$, and then its configuration including :

- 1 - the measuring range
- 2 - the status of the alarm
- 3 - action of the alarm (rising, falling or regulation action)
- 4 - the set point
- 5 - time-delay (dead band temporisation)

1- The measuring range

The following message is displayed : \overline{Lo} . This is the low value of the measuring range, and its digit value : **ex** : $\overline{-500}$.

The following message is displayed : \overline{Hi} . This is the high value of the measuring range and its digit value : **ex** : $\overline{1000}$.

The arrow displayed (at the bottom or on the right of the screen) is relative to the unit of measurement : **ex** : from -500 to 1000 Pa.

2 - The status of the alarm

When the alarm is off, the following message is displayed : \overline{ALOFF} .

When the alarm is on, the following message is displayed : \overline{ALON} .

- When the alarm is off, the transmitter displays $\overline{----}$, which confirms the end of initialization and that you can start the measurements .
- When the alarm is on, the transmitter displays the parameters relative to the relay (set point, program of the alarm, time-delay).

3 - Action of the alarm (rising or falling action)

If the relay is programmed in rising action, the following message is displayed : $\overline{- - r -}$.

If the relay is programmed in falling action, the following message is displayed : $\overline{- - l -}$.

This message is displayed : **ex** : $\overline{250}$, which means that the alarm

If the relay is programmed in regulation mode, the following message is displayed $\overline{0 -}$.

4- The set point (alarm on)

This message is displayed : **ex** : $\overline{250}$, which means that the alarm will be activated as soon as the measurement exceeds this value.

If you chose regulation mode $\overline{0 -}$, the second set point will appear.

5- The time-delay (alarm on)

This message is displayed : $\overline{15E}$.

The temporisation is in seconds (from 0 to 60 sec.).

After having displayed the configuration, the transmitter displays $\overline{----}$, which confirms that the initialization is finished and you can start the measurements.

■ Configuration via software (with optional LCC100 software)

An easy and friendly way to configure!

You can configure the measuring units, the set point, the time-delay...

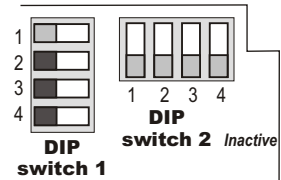

- To access the configuration via software, you must first position the **DIP switches** as per the following picture (shown beside), and then connect the cable to the transmitter (see connection drawing).

- Please refer to the user manual of the LCC 100 to make the configuration.

⚠ Caution !

The configuration can be made either by switch, or by software (you can not combine both solutions)



■ Mounting

Installation : mount the ABS plate on the wall (this plate is supplied with the transmitter). Drilling : \varnothing 6 mm, with the screws and pins supplied with the transmitter. Insert the transmitter into the plate (see points A of the drawing beside), by tilting it at 30°. Rotate the housing in clockwise direction until you hear a "click" which confirms that the transmitter is correctly installed.

⚠ Caution !

Once the transmitter is installed and energized, please proceed to an autozero to guarantee the correct working of the transmitter, whatever the position of the transmitter is.

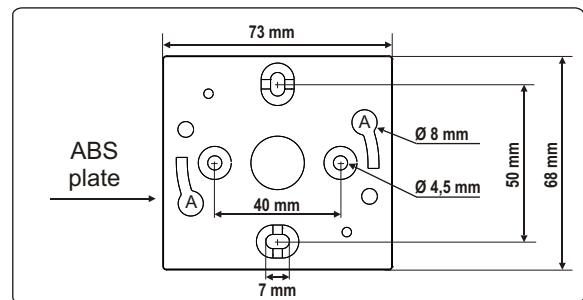

■ Maintenance

Please avoid any aggressive solvent.

Please protect the transmitter and its probes from any cleaning product containing formol, that may be used for cleaning rooms or ducts.

■ Options

- Power supply class 2, input 230 Vac, output 24 Vac, ref.KIAL-100A
- Configuration software LCC 100 with RS 232 connection cable



■ Optional accessories

- Connection tubes
- Connection fittings
- Wall through connections
- Junctions
- Coupling nut

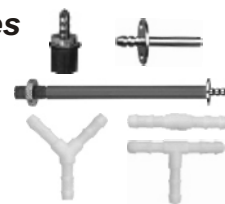

www.kimo.fr

Distributed by :

EXPORT DEPARTMENT

Tel : +33. 1. 60. 06. 69. 25 - Fax : +33. 1. 60. 06. 69. 29

e-mail : export@kimo.fr

